

Description

The DC3361P1 is a 3.3V bi-directional ESD protection diode, utilizing leading monolithic silicon technology to provide fast response time and ultra low ESD clamping voltage, making this device an ideal solution for protecting voltage sensitive data and power line. The DC3361P1 complies with the IEC 61000-4-2 (ESD) standard with $\pm 30\text{kV}$ air and $\pm 30\text{kV}$ contact discharge. It is assembled into an ultra-small 1.0 x 0.6 x 0.5mm lead-free DFN package. The small size and high ESD surge protection make DC3361P1 an ideal choice to protect cell phone, digital cameras, audio players and many other portable applications.

Features

- ◆ Ultra small package: 1.0 x 0.6 x 0.5mm
- ◆ Protects one data line
- ◆ Ultra low leakage: nA level
- ◆ Operating voltage: 3.3V
- ◆ Ultra low clamping voltage
- ◆ Complies with following standards:
 - IEC 61000-4-2 (ESD) immunity test
Air discharge: $\pm 30\text{kV}$
Contact discharge: $\pm 30\text{kV}$
 - IEC61000-4-5 (Lightning) 2.5A (8/20 μs)
- ◆ RoHS Compliant

Mechanical Characteristics

- ◆ Package: DFN1006-2 (1.0 x 0.6 x 0.5mm)
- ◆ Case Material: "Green" Molding Compound.
- ◆ Moisture Sensitivity: Level 3 per J-STD-020
- ◆ Terminal Connections: See Diagram Below
- ◆ Marking Information: See Below

Applications

- ◆ Cellular Handsets and Accessories
- ◆ Personal Digital Assistants
- ◆ Notebooks and Handhelds
- ◆ Portable Instrumentation
- ◆ Digital Cameras
- ◆ Peripherals
- ◆ Audio Players
- ◆ Keypads, Side Keys, LCD Displays

Dimensions and Pin Configuration

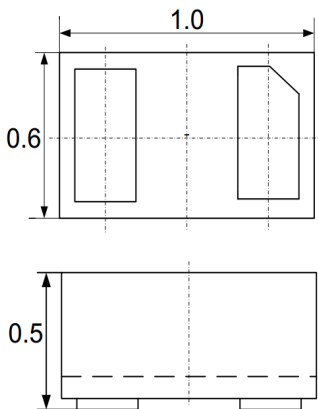

Package Dimensions

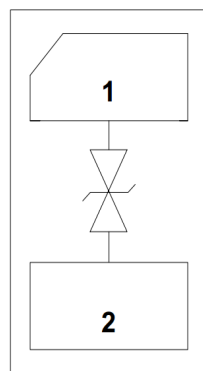

Circuit and Pin Schematic

Marking Information

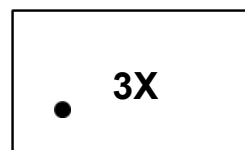

3X= Device Marking Code
Dot denotes pin1

Ordering Information

Part Number	Marking	Packaging	Reel Size
DC3361P1	3X	10000/Tape & Reel	7 inch

Absolute Maximum Ratings ($T_A=25^{\circ}\text{C}$ unless otherwise specified)

Parameter	Symbol	Value	Unit
Peak Pulse Power(8/20 μs)	Ppk	25	W
Peak Pulse Current(8/20 μs)	I _{PP}	2.5	A
ESD per IEC 61000-4-2 (Air) ESD per IEC 61000-4-2 (Contact)	V _{ESD}	± 30 ± 30	kV
Operating Temperature Range	T _J	-55 to +125	$^{\circ}\text{C}$
Storage Temperature Range	T _{stg}	-55 to +150	$^{\circ}\text{C}$

Electrical Characteristics ($T_A=25^{\circ}\text{C}$ unless otherwise specified)

Parameter	Symbol	Min	Typ	Max	Unit	Test Condition
Reverse Working Voltage	V _{RWM}			3.3	V	Pin 1 to Pin 2 or Pin 2 to Pin 1
Breakdown Voltage	V _{BR}	4.3			V	I _T = 1mA, Pin 1 to Pin 2 or Pin 1 to Pin 2
Reverse Leakage Current	I _R			0.2	μA	V _{RWM} = 3.3V, Pin 1 to Pin 2 or Pin 1 to Pin 2
Clamping Voltage	V _C			10	V	I _{PP} = 2.5A (8 x 20 μs pulse), Pin 1 to Pin 2 or Pin 1 to Pin 2
Junction Capacitance	C _J		3		pF	V _R = 0V, f = 1MHz

Typical Performance Characteristics (TA=25°C unless otherwise Specified)

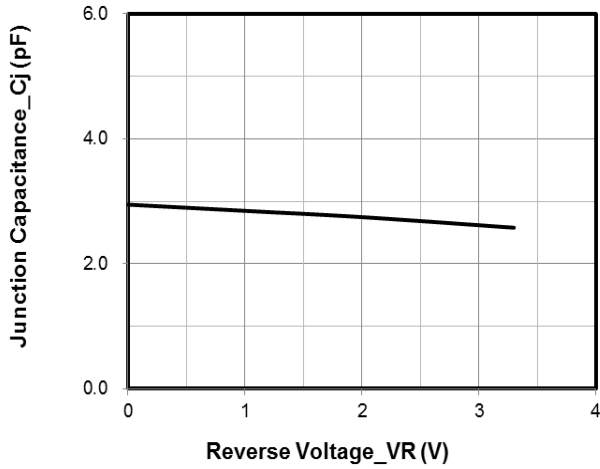

Junction Capacitance vs. Reverse Voltage

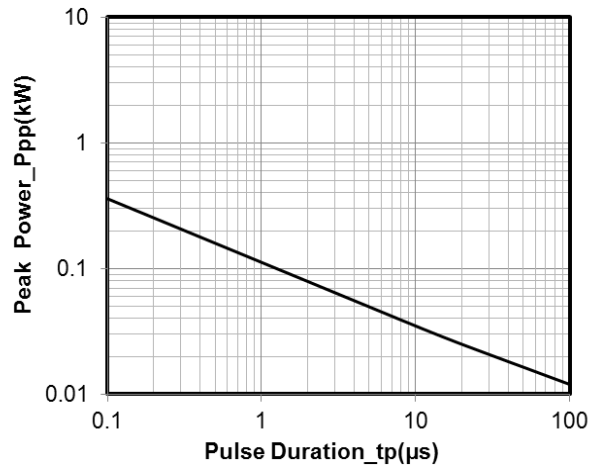

Peak Pulse Power vs. Pulse Time

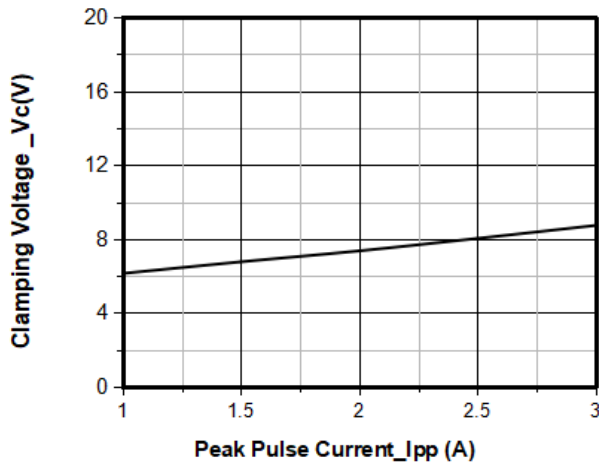

Clamping Voltage vs. Peak Pulse Current

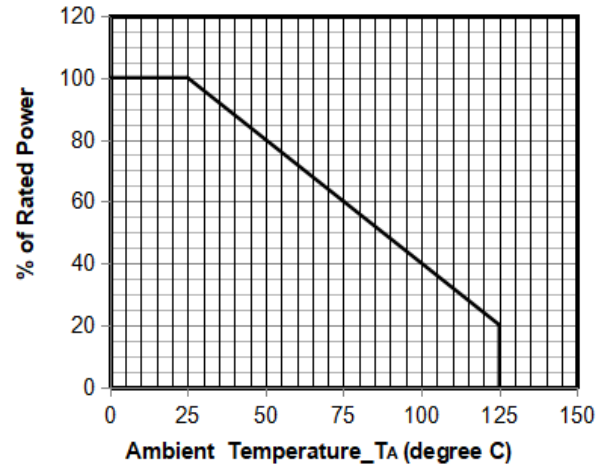

Power Derating Curve

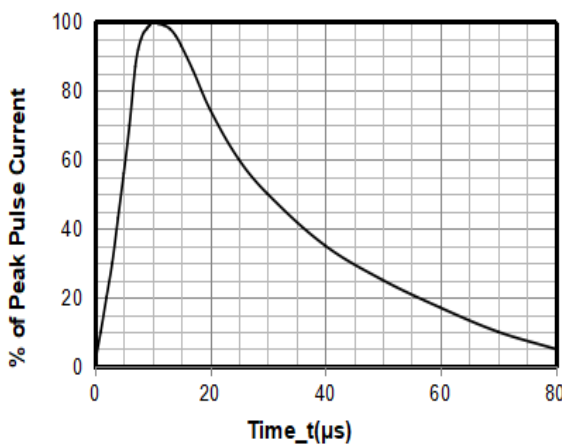

8 X 20μs Pulse Waveform

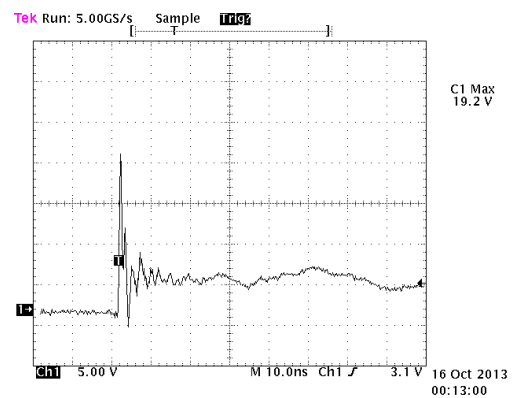

Note: Data is taken with a 10x attenuator

ESD Clamping Voltage

8 kV Contact per IEC61000-4-2

DFN1006-2 Package Outline Drawing

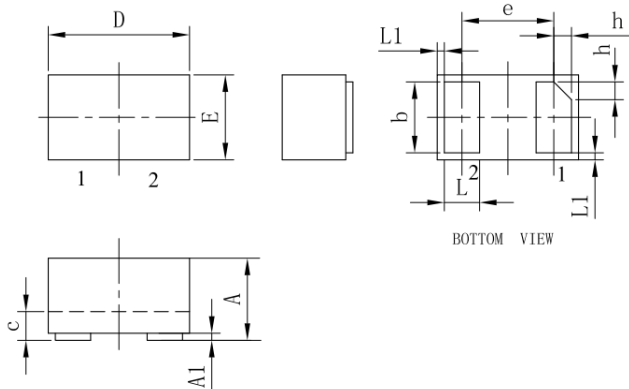

SYM	DIMENSIONS					
	MILLIMETERS			INCHES		
	MIN	NOM	MAX	MIN	NOM	MAX
A	0.450	0.500	0.550	0.018	0.020	0.022
A1	0.000	0.020	0.050	0.000	0.001	0.002
b	0.450	0.50	0.550	0.018	0.020	0.022
c	0.120	0.150	0.180	0.005	0.006	0.007
D	0.950	1.000	1.050	0.037	0.039	0.041
e	0.65 BSC			0.026 BSC		
E	0.55	0.60	0.65	0.022	0.024	0.026
L	0.20	0.25	0.30	0.008	0.010	0.012
L1	0.05REF			0.002REF		
h	0.07	0.12	0.17	0.003	0.005	0.007

Suggested Land Pattern

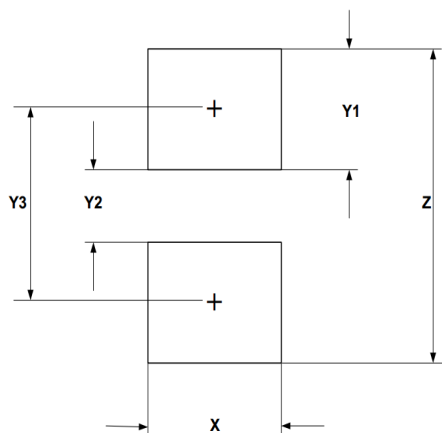

SYM	DIMENSIONS	
	MILLIMETERS	INCHES
X	0.60	0.024
Y1	0.50	0.020
Y2	0.30	0.012
Y3	0.80	0.032
Z	1.30	0.052

Contact Information

Changzhou D-first Electronics CO.,Ltd.
 www.first-electronic.com
 Email: xhf@first-electronic.cn
 Phone: +86 (0519) 8817 1671